



## Diesel Generator Sets

## GUANGZHOU WANON ELECTRIC AND MACHINE CO., LTD

**1.886** billion

"SAONON" brand is worth  
1.886 billion yuan

more than **100**

patented technologies

more than **20**

series of high-tech products



Founded in 2005, WANON covers an area of 20,000 square meters and has a registered capital of 110.5 million yuan. As a diversified high-tech enterprise, WANON is specialized in the R&D, design, production, sales and after-sales service of mechanical and electrical (M&E) products. Over the years, WANON has been committed to providing clients at home and abroad with all-round services, including technical consultation, complete machine and parts supply, project contracting, maintenance and personnel training, etc. The product portfolio covers onshore diesel generator units, marine diesel generator units, high-voltage generator units, gas generator units, etc., which are widely used in electric power, communications, transportation, energy, industry and mining, medical care, financial systems, data centers and other sectors. Therefore, WANON has won the trust of users.

Rated as "Guangzhou Enterprise Technology Center", WANON's R&D Center has more than 60 professional R&D personnel, and has built a cutting-edge intelligent multifunctional generator unit laboratory. Today, WANON has 3 subsidiaries, a nationwide after-sales service network, and its products are sold to more than 80 countries and regions in the Middle East, Southeast Asia, Africa, and Europe.

WANON is the first diesel generator manufacturer included on the list of "China's 500 Most Valuable Brands", and the brand value of its "SAONON" is 1.886 billion yuan. WANON has been recognized as a national high-tech enterprise, and has more than 100 patented technologies including invention patents. WANON has passed the system certification of ISO 9001, ISO 14001, OHSAS 18001, and GJB 9001B, and its products have passed such

certification as EU CE, TLC, and CCC. Its 22 series products have been rated as "Guangdong High-tech Products". The SAONON generating units have been identified as a famous brand product in Guangdong Province, and the trademark "SAONON" has been recognized as a famous brand in Guangdong Province. Additionally, WANON has been rated as the "AAAA Standardized Good Behavior Enterprise" in Guangdong Province, "AAA Credit Enterprise of Mechanical and Electrical Import and Export Enterprise" in China, and has kept the title of the Contract-abiding and Credit-worthy Enterprise in Guangdong Province for 12 consecutive years.

In September 2015, the China Securities Regulatory Commission unconditionally passed the major asset reorganization project of LONCIN MOTOR (stock code: 603766) to purchase WANON's mechanical and electrical assets. Through a win-win mode of strong cooperation and drawing on each other's strengths, a full-coverage industrial ecological chain featuring "household power supply + commercial smart power supply" was formed in the generator unit industry.

WANON has always been adhering to the corporate philosophy of "Superior Technology and Green Power", with the goal of building a world-class enterprise and an internationally renowned brand. Advancing with the times and constantly innovating, WANON is dedicated to providing reliable power solutions for clients, and to providing green electricity for the world.

# Contents

SC Series .....	01
SYC Series .....	03
SSM Series .....	05
SYM Series .....	06
SAONON Generator Set .....	07
Open Type Generator Set .....	09
Silent Generator Set .....	11
Containerized Generator Set .....	13
Ultra Silent Generator Set .....	15
Australian Standard Generator Set .....	16
Longtime Maintenance-free Generator Set .....	17
High Voltage Generator Set .....	18
Trailer Type Generator Set .....	19
Power Supply Vehicle .....	20
Modular Power Station .....	21
Gas Generator Set .....	22
SAONON Control System .....	23
Automatic Transfer Switch(ATS) .....	24
Parallel System .....	25
Comprehensive Energy Management System .....	26



# SC Series



- 1 Internationally renowned powertrain make, high technology level, mature supporting equipment, and high reliability.
- 2 Professional engine manufacturing, and long-tested technology.
- 3 Low failure rate, and low maintenance cost, providing clients with the best economic benefits.
- 4 Strong technical strength, strong power, low fuel consumption, and low emissions, providing efficient and clean energy.
- 5 Wide range of market applications, service centers spreading all over the world, easy replacement of spare parts, and low cost.

## 50Hz 3Ph 400V Pf0.8

Open Type Model	Standby power		Prime Power		Cons 100% (L/h)	Open Type		Silent Canopy		Engine Specification				Alternator Model	
	kVA	kW	kVA	kW		Dimension L×W×H (mm)	Weight (kg)	Silent Canopy L×W×H (mm)	Weight (kg)	Engine Model	Dis.(L)	Cyl.	Lube Capacity (L)		Coolant Capacity (L)
S30HC	30	24	27	22	6.5	1900*790*1210	700	2200*1094*1454	1145	4B3.9-G2	3.9	4L	11	20	S0L2-P
S45HC	44	35	40	32	9.4	1950*790*1210	750	2200*1094*1454	1200	4BT3.9-G2	3.9	4L	11	20	S1L2-K
S55HC	55	44	50	40	11.7	1950*790*1235	780	2500*1094*1454	1260	4BTA3.9-G2	3.9	4L	11	23	S1L2-R
S88HC	88	70	80	64	16.2	2150*790*1255	970	2500*1094*1454	1435	4BTA3.9-G11	3.9	4L	11	23	UCI224G
S105HC	105	84	95	76	18.8	2100*790*1320	980	2500*1094*1454	1470	4BTA3.9-G13	3.9	4L	11	23	UCI274C
S110HC	110	88	100	80	22.9	2150*935*1270	1020	2800*1144*1554	1680	6BT5.9-G2	5.9	6L	16	24	UCI274C
S150HC	150	120	138	110	29.5	2350*935*1280	1300	3100*1244*1681	1980	6BTAA5.9-G2	5.9	6L	16	28	UCI274E
S165HC	165	132	150	120	34.8	2400*935*1360	1310	3100*1244*1681	2025	6BTAA5.9-G12	5.9	6L	16	28	UCI274F
S200HC	200	160	182	145	41.2	2400*935*1360	1600	3600*1294*1984	2550	6CTA8.3-G2	8.3	6L	28	32	UCI274G
S220HC	220	176	200	160	43.3	2500*1035*1395	1700	3600*1294*1984	2650	6CTAA8.3-G2	8.3	6L	24	34	UCI274H
S275HC	275	220	250	200	53	2650*1035*1500	2000	3600*1294*1984	2900	6LTAA8.9-G2	8.9	6L	28	35	S4L1S-C4
S500HC	500	400	475	380	96.5	3200*1400*1915	3300	4400*1544*2234	4850	QSZ13-G3	13	6L	45	75	S5L1D-C4
S315CC	315	250	275	220	61	3050*1100*1750	2800	4000*1444*2134	3900	NTA855-G1A	14	6L	39	61	S4L1D-D4
S350CC	350	280	313	250	68.3	3050*1100*1750	2880	4000*1444*2134	3990	NTA855-G1B	14	6L	39	61	S4L1D-E4
S375CC	375	300	344	275	72	3050*1100*1750	2880	4000*1444*2134	4000	NTA855-G2A	14	6L	39	68	S4L1D-E4
S415CC	415	330	375	300	83.5	3150*1130*1755	3000	4000*1444*2134	4150	NTAA855-G7	14	6L	39	76	S4L1D-F4
S440CC	440	352	400	320	87	3300*1025*1770	3300	4400*1544*2234	4800	QSNT-G3	14	6L	39	84	S4L1D-F4
S500CC	500	400	450	360	98.8	3300*1230*1770	3250	4400*1544*2234	4850	QSNT-G4X	14	6L	39	84	S4L1D-G4
S550CC	550	440	500	400	94.6	3450*1380*1900	3500	4650*1744*2434	5400	KTA19-G3A	18.9	6L	50	89	S5L1D-C4
S650CC	650	520	/	/	126	3450*1380*1900	4000	4650*1744*2434	5680	KTA19-G8	18.9	6L	50	98	S5L1D-E4
S688CC	688	550	/	/	128	3650*1500*2105	4100	5000*1844*2534	5850	KTAA19-G6A	18.9	6L	50	122	S5L1D-F4
S715CC	715	570	650	520	145	3700*1700*2215	4750	5600*2144*2604	7500	QSK19-G4	18.9	6L	84	133	S5L1D-F4
S750CC	750	600	680	545	143	3700*1690*2115	4800	5600*2144*2604	7650	QSK19-G19	18.9	6L	84	122	S5L1D-G4
S825CC	825	660	750	600	167	4200*1805*2385	6700	5600*2144*2604	7800	KTA38-G2	37.8	12V	135	259	S5L1D-H4
S880CC	880	720	800	640	169	4200*1805*2385	6800	5900*2294*2604	9200	KTA38-G2B	37.8	12V	135	263	S6L1D-C4
S880CC	880	720	800	640	167	3700*1690*2112	4850	5900*2294*2604	9300	QSK19-G21	18.9	6L	84	122	S6L1D-C4
S1000CC	1000	800	910	728	196	4200*1805*2385	6800	5900*2294*2604	9600	KTA38-G2A	37.8	12V	135	263	S6L1D-D4
S1100CC	1100	880	1000	800	209	4350*2035*2320	6900	5900*2294*2604	9750	KTA38-G5	37.8	12V	135	263	S6L1D-E4
S1250CC	1250	1000	/	/	210	4350*2035*2320	7200	6400*2294*2604	10500	KTA38-G9	37.8	12V	135	289	S6L1D-F4
S1375CC	1375	1100	1250	1000	254	5000*2035*2375	9700	6800*2294*2604	12500	KTA50-G3	50	16V	177	351	S6L1D-G4
S1500CC	1500	1200	1375	1100	291	4600*2200*2200	8200	6800*2294*2604	14500	QSK38-G13	37.8	12V	117	360	S6L1D-H4
S1650CC	1650	1320	1500	1200	309	5600*2160*2480	10400	12192*2438*2896	18500	KTA50-GS8	50	16V	204	445	S7L1D-C4
S1750CC	1750	1400	1600	1280	334	4800*2300*2200	8500	12192*2438*2896	17300	QSK38-G15	37.8	12V	117	360	S7L1D-D4
S1875CC	1875	1500	1675	1340	359	5700*2160*2655	10800	12192*2438*2896	19100	KTA50-G15A	50	16V	204	460	S7L1D-E4
S2000CC	2000	1600	1875	1500	402	5450*2220*2820	10900	12192*2438*2896	19200	KTA50-G16A	50	16V	234.7	460	S7L1D-F4
S2250EC	2250	1800	2000	1600	434	6000*2500*3000	16000	/	/	QSK60-G4	60	16V	280	242*	S7L1D-G4
S2500EC	2500	2000	2250	1800	449	6200*2500*3000	16500	/	/	QSK60-G8	60	16V	280	242*	S7L1D-H4
S2750EC	2750	2200	2500	2000	497	6500*2568*2767	17000	/	/	QSK60-G23	60	16V	280	242*	S7L1D-J4
S3000EC	3000	2400	2750	2200	528	6950*2744*3318	22000	/	/	QSK78-G9	78	18V	466	295*	LVS1804S

- The accurate data is subject to the final delivery of the order. Please confirm with the technical staff if necessary.
- With "\*" mark only refers to the engine capacity, not including water tank and pipeline.

# SYC Series



50Hz 3Ph 400V Pf0.8

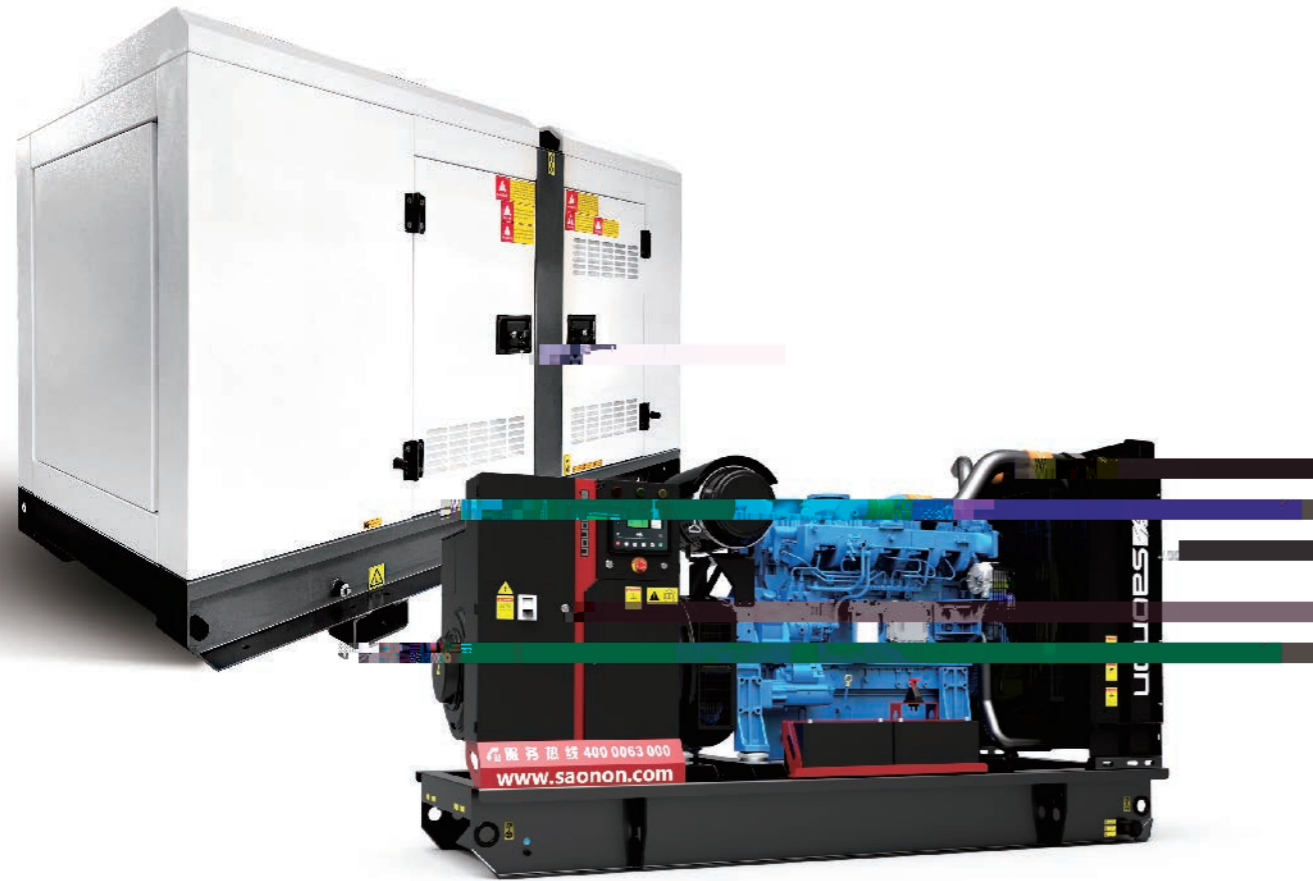

- 1 Wide range of applications and wide power coverage.
- 2 International technology platform, and mature technology.
- 3 Various types of emissions to meet the needs of different users.
- 4 Small vibration, low noise, and high reliability.
- 5 Convenient after-sales service. The service network covers many countries and regions around the world.



# SAONON Generator Set

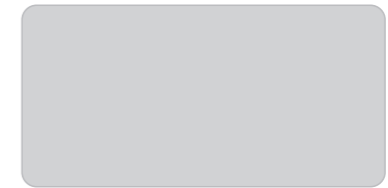
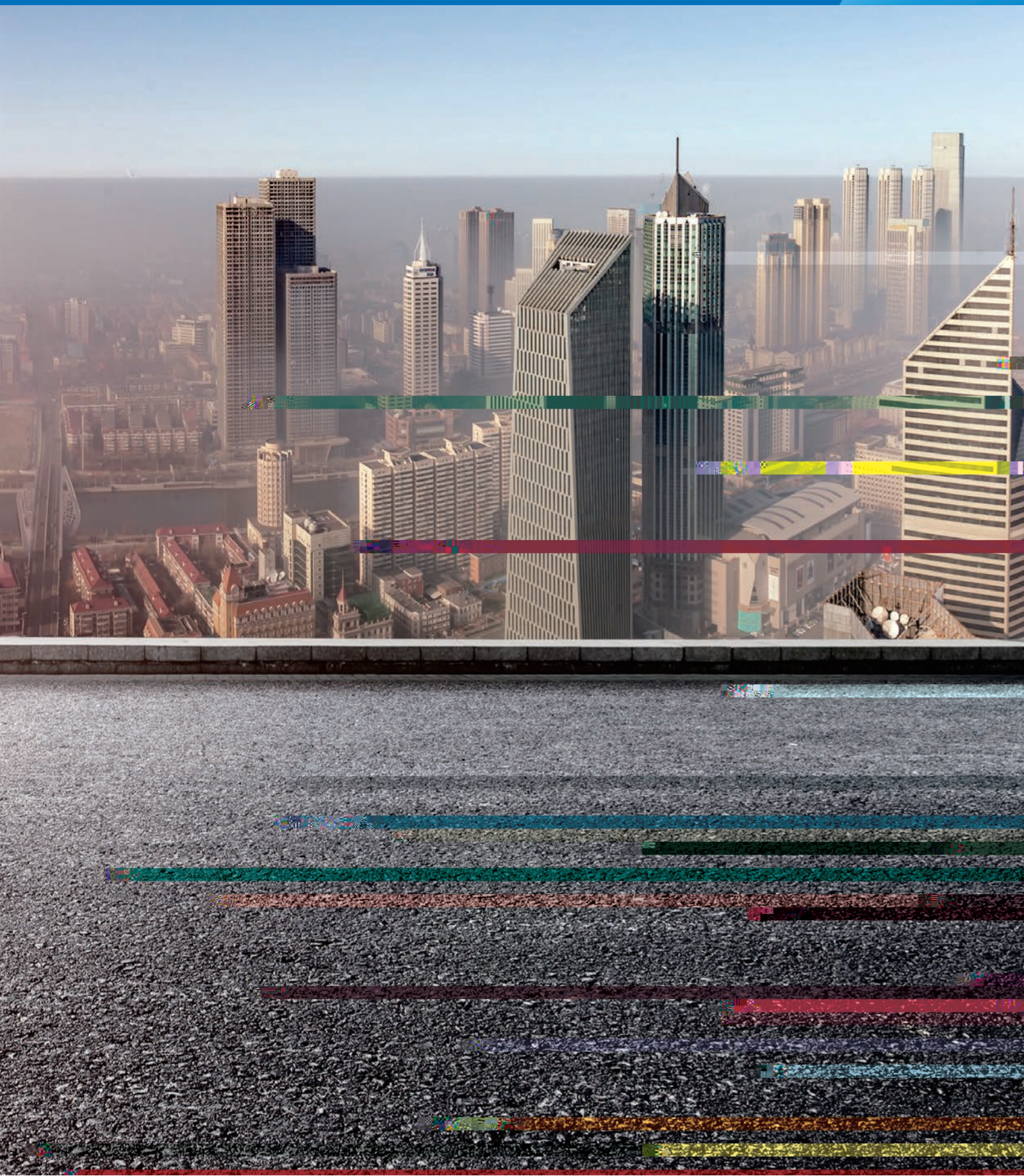

## SAFETY

### ■ Transportation

- 
- 

### ■ High temperature protection

- 
- 
- 

### ■ Operation

- 
- 
- 

### ■ Electrical system

- 
- 
-



Application fields: Open type generator sets are used as a regular or backup power supply in post and telecommunications, communications, hotels, buildings, entertainment venues, hospitals, shopping malls, industrial and mining enterprises, etc.

1. Breaker cabinet
2. Control panel
3. AC alternator
4. Air filter
5. Engine
6. Mounting flange of exhaust-pipe
7. Coolant inlet
8. Radiator
9. Base frame
10. Battery
11. Fuel level meter
12. Fuel inlet
13. Lifting lug
14. Vibration absorber

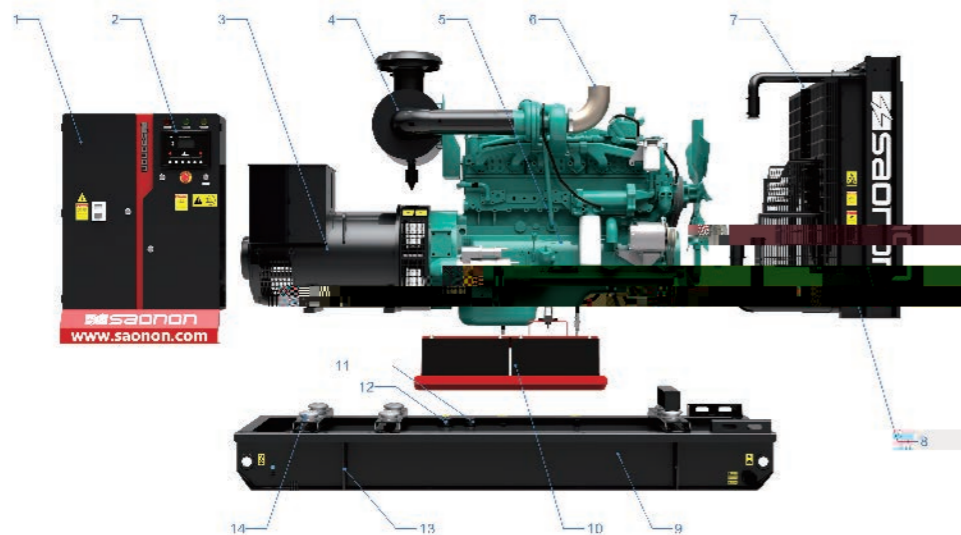

#### ■ Low fuel consumption

- Equipped with a high-efficiency fuel-saving device, which greatly reduces the fuel consumption rate of the unit.

#### ■ Low failure rate

- Engines and generators of world-renowned make are used to ensure that the unit can operate with load for

#### ■ Low maintenance cost

- Compact structure and small size, which can help minimize the transportation cost of clients.

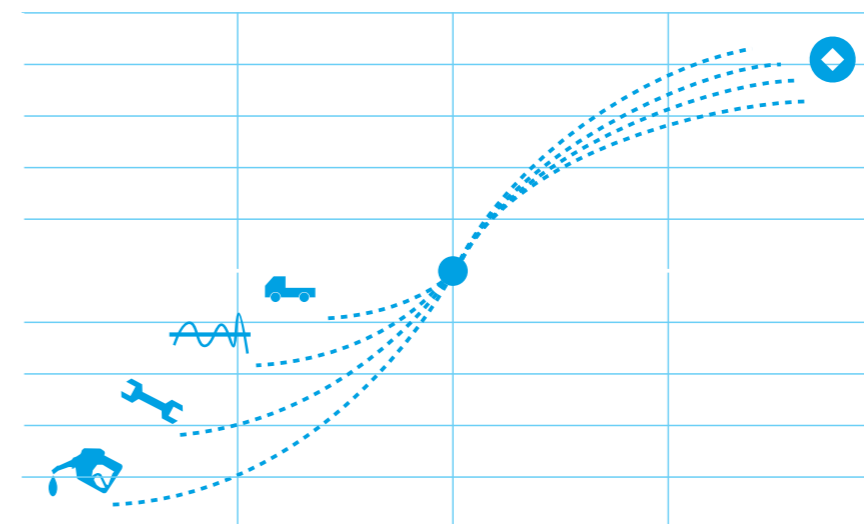





The noise level of silent generator sets can be reduced by 15-35dB (A) through multiple noise control devices, which ensure quiet operations, thus having no bad effect on daily activities. The silent genset is capable of working in residential areas, offices and other environments during night time which are sensitive to noise.

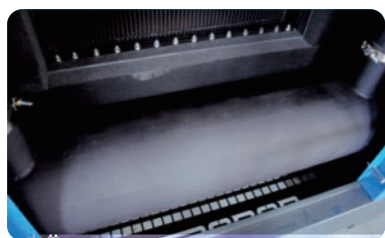

■ Superior muffler



■ Fully enclosed noise reduction



■ High-quality sound-absorbing material

■ Convenient fuel and water filling device

- 
- 
- 

■ Easy to handle

- 
- 

■ Easy to maintain and repair

- 
- 
- 
- 

■ Advanced waterproof, dustproof, sand-proof and ratproof design

- 

■ Excellent welding and spraying process

- 

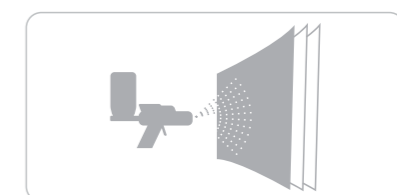



## Containerized Generator Set

Applicable to outdoor operations of large power stations or large-scale projects.

### ■ Noise reduction development

- The overhead muffler and exhaust pipe system may improve the container loading space and greatly provide convenience for machine maintenance.
- Noise reduction measures are taken for the interior of the container, including sound absorption and heat insulation for the four walls and top.

### ■ Built-in independent fuel tank

- Built-in large capacity independent fuel tank may meet the need of normal operation and use of the unit.

### ■ Safety design

- The container unit is designed to prevent rain and sand, which may effectively achieve the feasibility of use in windy and sandy areas. In addition, rodent-resistant nets are installed on external doors and windows to prevent small animals from entering the equipment and causing damage.

### ■ Easy to transport

- Standard containers are adapted to meet the requirements of national standards such as GB/T1413 and GB/T1992, as well as the requirements for sea and land transport.



Powerful engine and alternator



Compact internal structure



Built-in high-temperature protective material



Visual liquid level meter



Intelligent control system



External interface



Vent protection device



Beautiful and practical ventilation device



## Ultra Silent Generator Set

Multiple excellent noise reduction devices are employed, so that the noise level of the generator unit may be reduced by 15-35dB (A), and no impact would be imposed on daily life due to the quiet operation. The multiple excellent noise reduction devices are suitable for night work, high-end residential areas, office areas, and other places with high requirements for noise control.

### Product features

- The casing is well sealed, and is safe to use due to the good rainproof and dustproof performance.
- With a decibel value reduced by 5% compared to common static speakers of the same configuration, the ultra-low noise level meets the requirements of CE noise testing and national standard GB/T 2820.10.
- the structure of the casing may be optimized through fluid analysis to better control the intake and exhaust flow directions, and improve the internal temperature environment of the casing.
- CAE simulation analysis is implemented to ensure the structural strength and reduce the occurrence of unit resonant vibration;
- Large-capacity base fuel tank may be configured to meet the long-term operation of the unit.

### About ultra silent

- The overall structure is improved to ensure performance while blocking internal reverberation radiation to the exterior side of the casing.
- Materials with high sound absorption coefficient are used for the entire interior of the casing to effectively block and absorb internal noise.
- The intake and exhaust channels are equipped with mufflers to buffer the intake and exhaust noise in the channels. The mufflers are formed with aluminum perforated plates, which may not only ensure noise reduction performance, but also achieve lightweight design.
- The residential muffler designed based on engine exhaust parameters and calculation formulas has excellent performance and significant noise reduction effects. The special internal design may ensure that the surface temperature of the muffler is under control.

## Australian Standard Generator Set

Applicable to places with Australian standards or other offices and residences with high requirements.

### Australian environmental protection standards

- Double-layer fuel tank may achieve zero fuel leakage.
- Internal circulation of coolant may achieve no leakage or emission.
- The engine technology meets Australian national emission standards.
- The muting technology meets international noise standards.

### Convenient engineering design

- External refueling design and intuitive operation design.
- Fully open maintenance space.
- Integration of multiple transportation and movement schemes involving towing, lifting, and forking.
- Multiple protection including forklift guidance and towing port chamfering.

### Australian safety standards

- Standard electrical components conforming to AS/NZS3100-A3 are equipped as the standard configuration for the units.
- Leakage protection devices are equipped as the standard configuration to further improve the safety.
- Multiple groups of unique design to prevent misoperation may add another layer of protection for safety.
- Grille type air vent design can prevent the ingress of small animals into the unit.



## Longtime Maintenance-free Generator Set

Applicable to long-term unattended machine rooms, power stations, etc.

### ■ Design features

- Compact structure design convenient for use and maintenance.
- Sound-proof structure and low noise level: 55-80dB (A)@7m.
- Extra-large fuel tank design with reasonable structure and excellent plates, which may ensure safe use.
- The forklift holes and the equipped single point lifting holes make it easy for handling.

### ■ Free from maintenance within an extra-long period

- The automatic lubricating system may feed lubricating oil intelligently.
- Various filters are upgraded, with a service time of no less than 1000H.
- Ultra-large capacity underframe fuel tank may ensure that the operation time 168h.
- Intelligent control system supports remote control and ATS automatic load switching.
- Applicable to remote control startup and long-term unattended machine rooms, power stations, etc.

## High Voltage Generator Set

Applicable to industries, mines, data centers, airports and other facilities with large power demand.

### ■ High reliability

- The products meet relevant requirements of BS EN 60034 and other international standards (such as BS5000, VDE0530, IECEN60034, and As1359).
- Before delivery, the unit shall pass continuous on-load operation test, withstand voltage test, transient loading (sudden loading and unloading test), static test, wave recording, harmonic analysis, and other tests to ensure that all indicators of the unit meet the standard requirements.

### ■ Use safety

- **Operation safety**  
The complete power management system provided is applicable to parallel operation of HV units with complex load management;  
The perfect combination of digital parallel main control cabinet and digital generator controller constitutes an unattended fully automatic power management system, which may provide reliable guarantee from the perspective of operation and safety.
- **Electrical safety**  
High-performance automatic voltage regulator, which may withstand a short circuit current of 300% of the maximum rated current, is equipped to provide effective protection for the generator unit;  
The air switch of the unit is of a fully automatic closing mode. When the current in the circuit is too strong or short circuit occurs, the switch will automatically open immediately.

### ■ Economical and convenient

- **Low fuel consumption and low operating costs**  
High voltage and low output current may effectively reduce power loss during power transmission and improve power transmission distance, so as to reduce the overall cost.
- **Low failure rate and low maintenance cost**  
The unit has simple system and only a few parallel equipment, which makes it easy to use. In addition, it requires low equipment maintenance cost due to few fault points;  
The mean time between failures of the unit is no less than 1,000 hours.



## Trailer Type Generator Set

Applicable to open-air and outdoor power supply sites.

### ■ Travel safety

- Wheel chocks and supports are equipped as the standard configuration to ensure parking safety.
- Guide pulleys and traction chains are provided to ensure travel safety.
- Drum brake, pneumatic brake, and hydraulic brake are optional to ensure brake safety.
- Warning lights, turn lights, and reflective stickers are equipped to ensure passive safety.
- Uniform load distribution makes it more convenient to travel and park.

### ■ Damping system

- Shear resistant damping rubber pads are used between the engine, generator and base to effectively reduce vibration and make operation more stable.
- Excellent base materials are selected to further improve the damping effect.

### ■ Easy to move

- The trailer chassis is equipped with functional accessories that may be towed or pulled, making it easy to use and meeting the requirements of mining, road engineering, and other industries for the operating environment.
- The economical unit size design may reduce transport costs.
- Foldable trailer makes the turning radius adjustable.
- The double hanger structure of the entire unit may ensure stable center of gravity for lifting without affecting the space for operation and maintenance.

### ■ User-friendly design

- Hydromechanical static speaker casing makes it lighter and quieter.
- Fully automatic intelligent module may achieve simple and convenient operation.
- Ergonomic layout makes it easy for observation and operation.
- Spare parts of various brands are applicable, which makes the unit of high versatility.

## Power Supply Vehicle

Applicable to emergency power for rescue and relief and emergencies.

### ■ Safe driving

- Large capacity of tank for long working hours.
- Systematic design with complete devices.
- Multiple modes of voltage output for different circumstances.
- Advanced power control system for reliable power supply.
- 
- 

### ■ Design features

- 
- 
- 
- 
- 
-



## Modular Power Station

1MW container generator unit will be your best choice as a regular/backup power source for leasing, mining and oil & gas industry with low noise (65dB (A)/7m), convenience of transport and safe and reliable operation.

### ■ Abundant electric energy

- Stable 1MW power output, 20-foot standard container for upgraded power generation density.
- Compliance with ISO and CCS requirements and easy loading and transportation for fast power transmission and distribution.
- Compact design making the best of the container space for independent functional ability of the generating unit.

### ■ Function expansion

- Visual window with intelligent control unit of parallel operation and connection function.
- Optional automatic lubricating oil filling system to ensure safe lubricating.
- Optional jacket heater to ensure normal start at low temperature.
- Optional air cut off valve and active spray to prevent fire.

### ■ Simple design

- External emergency stop switch.
- External fuel filling port and return port.
- Large-space access door.
- Audible and visual alarm device.
- Built-in ladder.
- Trailer behind the container.

## Gas Generator Set

Suitable for places rich in gas, such as the natural gas landfill and biogas digester.

### ■ High efficiency

- High generating efficiency: more than 40%.
- Comprehensive utilization efficiency: nearly 90%.
- High performance density.
- Long maintenance interval.
- Low operating cost in the life cycle.

### ■ High environmental benefit

- Low emission reduces greenhouse gas emission.
- Use of renewable gas.
- High overall efficiency.
- (nitrogen oxide emission <math>250\text{ppm}</math>).

### ■ A variety of fuels

- Natural gas.
- Renewable gas.
- Sewage biogas and landfill gas.
- Oilfield associated gas, etc.

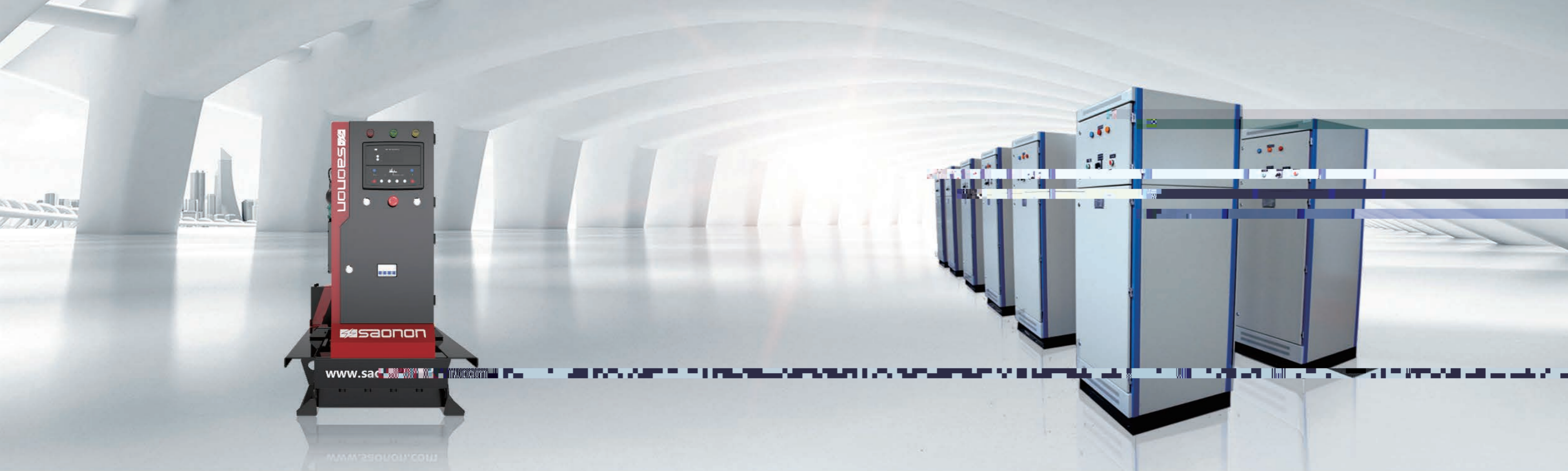

## SAONON Control System

## Automatic Transfer Switch(ATS)

The system is mainly used to control the special devices for automatic switching between the one-circuit generation of the diesel generator unit and one-circuit mains supply. It integrates the digital, intelligent and network technologies for startup and shutdown control, real-time monitoring and data measurement, alarm and protection of generator units. It can also monitor the quality of mains supply and automatically control the startup of the generator units when the mains supply deviates from the set value or power outage occurs, realizing switching between the mains supply and generation.

### Product features

- Manual/automatic function.
- AMF and ATS function.
- Display of engine parameters, generator parameters, power parameters and mains supply parameters.
- Mains supply detection can be disabled if not required.
- Monitoring and protection of the engine, generator and mains supply.
- Preset of two operating modes and protection parameters.
- Upgrading of software version.
- Preset of the operating time (regular startup and maintenance of the sets) .
- Oil pressure and water temperature sensor with line self-diagnosis function.
- Icon display alarm.
- Multiple languages.

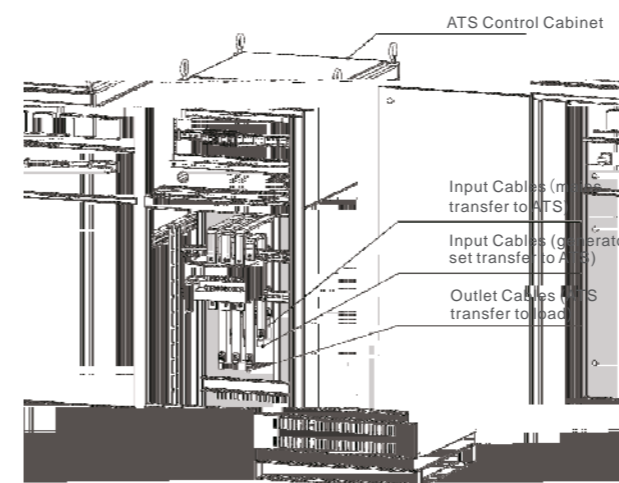

### Product features

- The generator is of steel structure and the door panel is hinged and lockable.
- Powder coating is applied to the surface.
- All the cover plates on the base within the rated range are removable to facilitate cable access.
- Top cover is provided for some models.
- Voltmeter is provided to measure the output voltage.
- Power switching button is provided.
- Grounding busbar is provided.

